

RIG04: Kite Aerial Photography Altimeter, Logger, and Controller

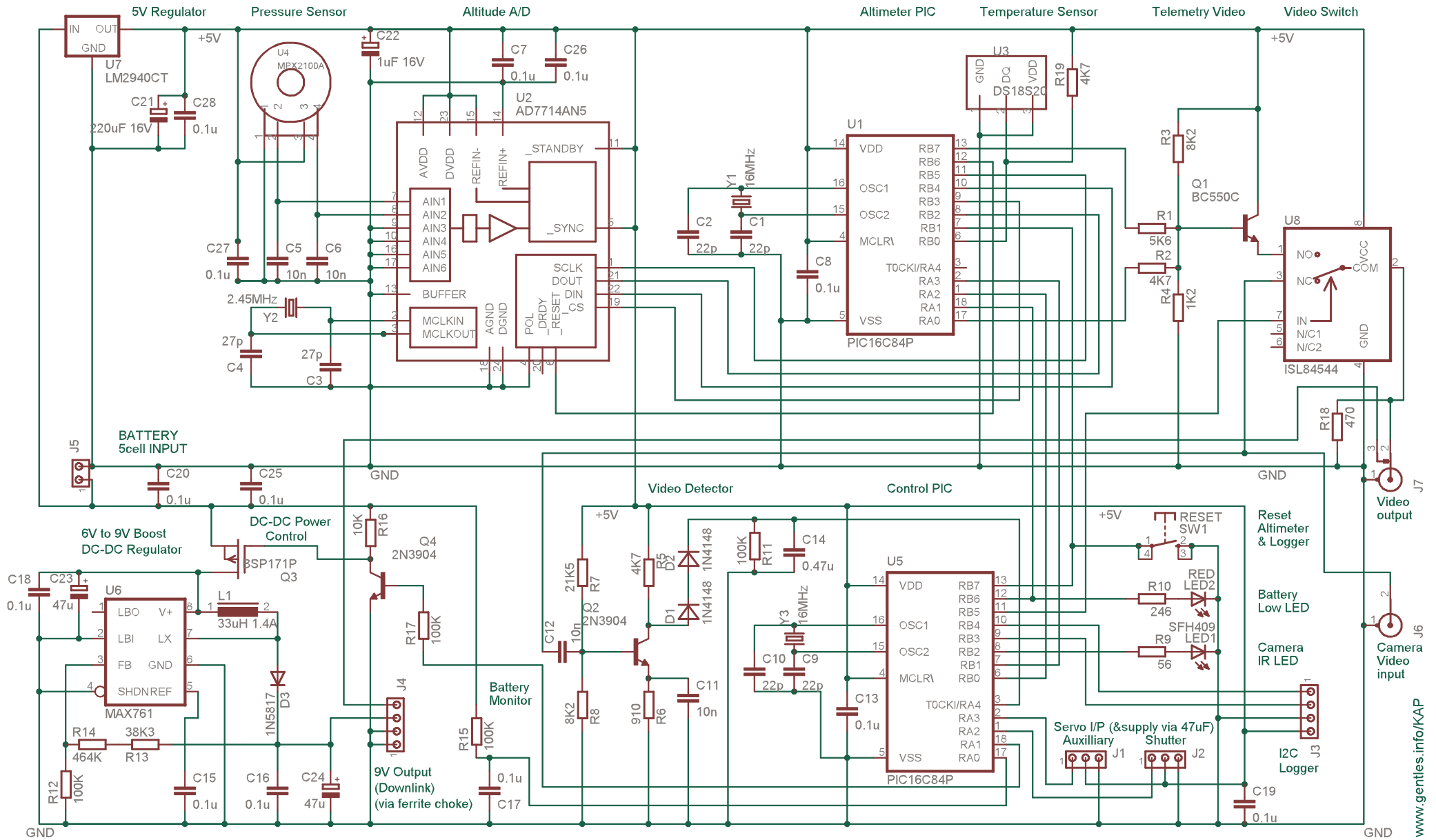

RIG 04: Mechanical Details (1 of 2)

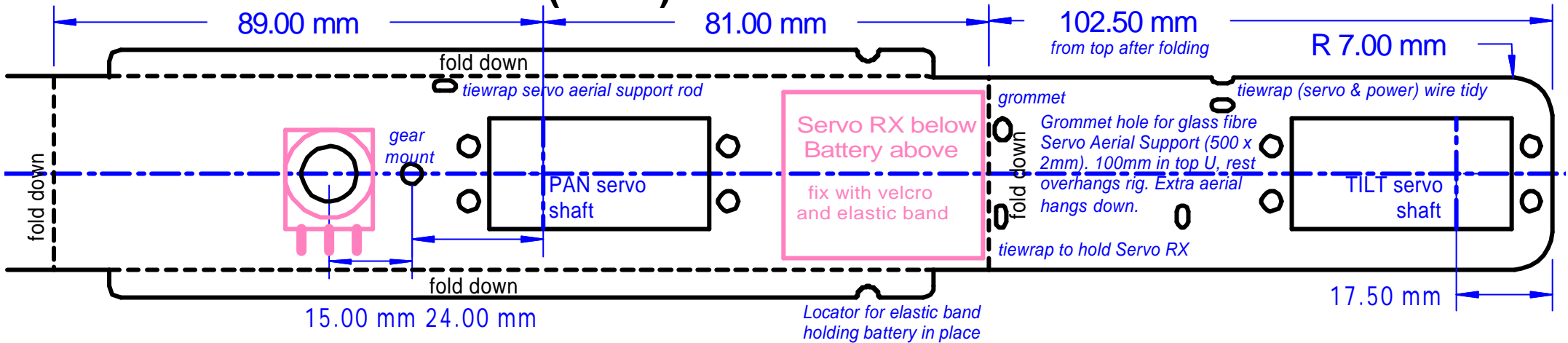

Top U Bracket (top view)

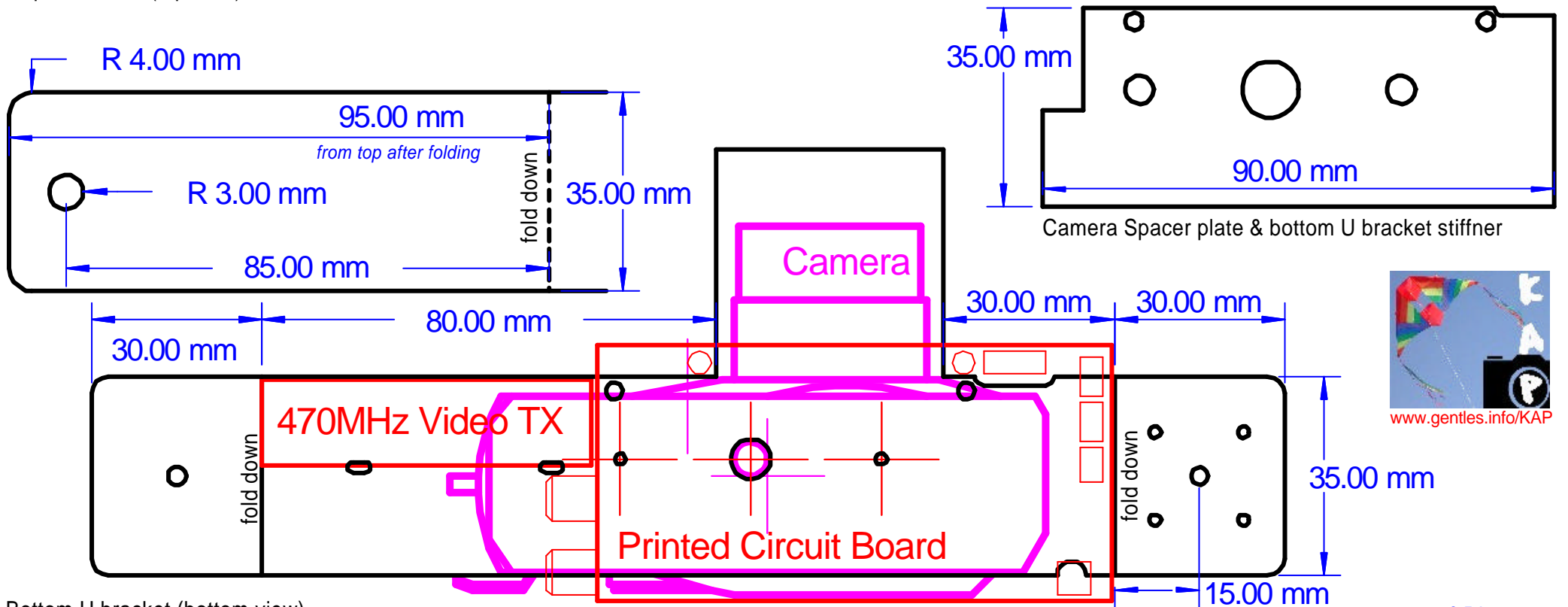

Bottom U bracket (bottom view)



RIG 04: Mechanical Details (2 of 2)



M4 bolt attached to suspension via a nylock nut reversed onto the shaft and a M4 wing nut. A small hole is located in the top of the bolt for a retaining clip (made from a cut down kirby-grip)

M4 x 65mm bolt held with M4 nylock nut

4x M2.5 bolts connect servo to first gear.

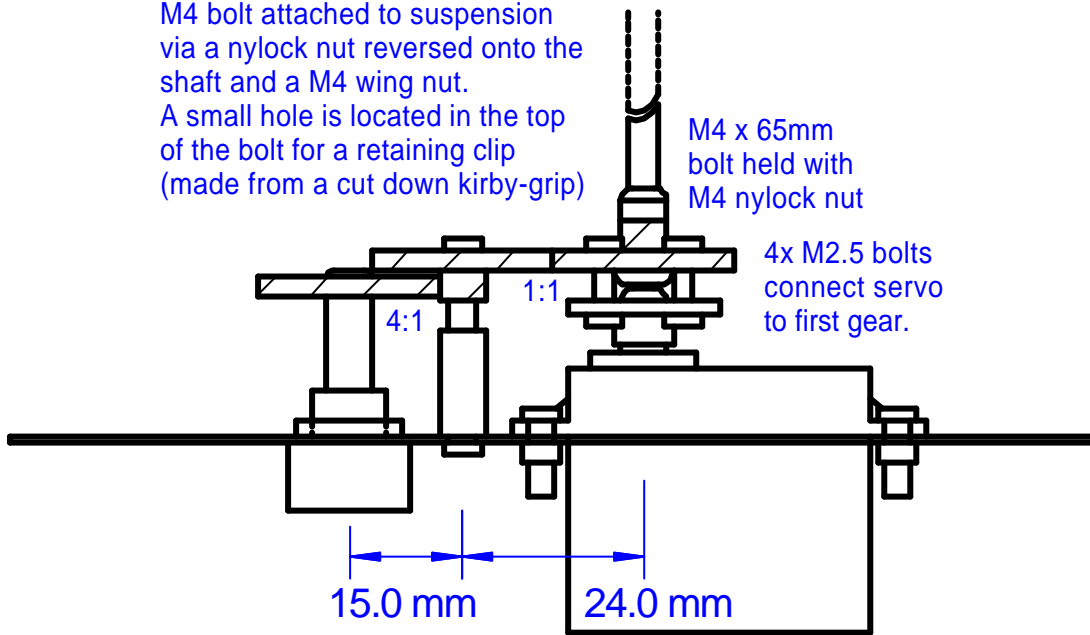

Pan Servo & feedback gears Detailed Elevation

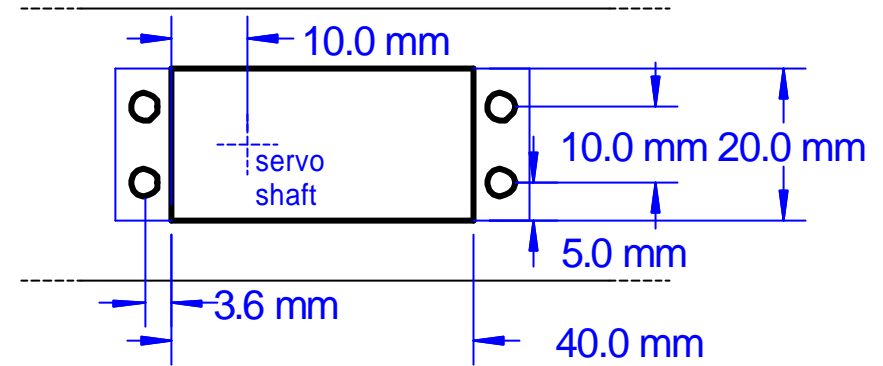

Detail cut-out for JP STANDARD Servo

R 4.2 mm
8.5 mm

The radials are made of two pieces of 1mm copper wire, bent and soldered as shown above to form a ring that is trapped between the male Phono and it's plastic cover. The aerial and radials are held out from the rig by 300mm on a 2mm carbon rod which also supports a thin coax aerial lead, which has a metal phono on the rig end and a plastic phono socket on the aerial end, both tiwrapped to the rod. The overall length of the completed radial set should be 325mm (the full length is not shown in the drawing).

Plastic phono plug.
Secure radials between plug and plastic cover



70cm Aerial and groundplane diagram

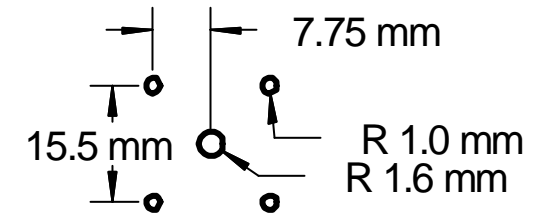

Tilt Servo template for bottom U

RIG 04: Ground Circuit Diagrams & Layouts



www.gentles.info/KAP

*This circuit tries to make sure that you don't leave the transmitter on!
As well as an ON light that fades as the voltage drops, there are two thresholds, one for a RED light, and a lower one still for a BUZZER. The RED light says stop KAPing, the BUZZER is for the car boot!
The circuit shows a number of variations on a theme. Note the circuit can be made from NPN or PNP transistors, and also the fixed and variable voltage set points.*

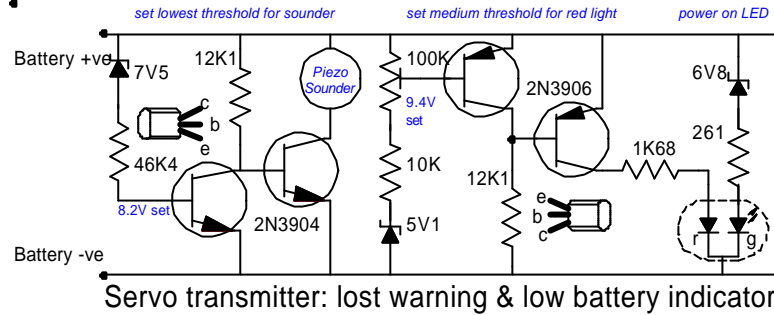

Servo transmitter: lost warning & low battery indicator

These resistor chains are designed to replace standard 5Kohm joystick potentiometers, and provide the logically and ergonomically better rotary control solution for KAP. The PAN and TILT are simple resistor chains with presets to allow you control over the end-stops in a similar way to the trims on the joysticks. The SHUTTER and ZOOM show how to provide a single and double position switch, again with a trim control. The circuits are designed so that there is never a high or low resistance presented momentarily as the switch is changed. This could result in servo jitter on all channels, not just the servo being switched.

Channel 1: PAN

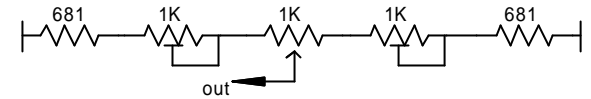

Channel 2: TILT

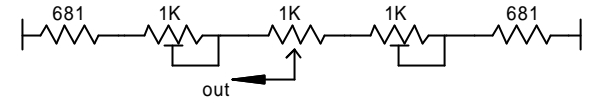

Channel 3: ZOOM

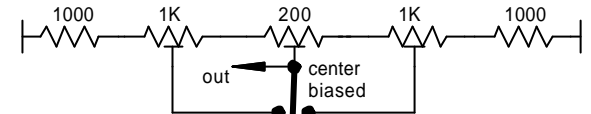

Channel 4: SHUTTER / POWER

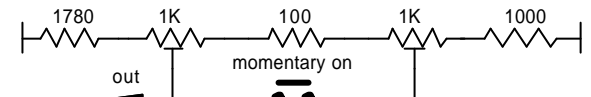

Resistor Networks to replace servo joysticks

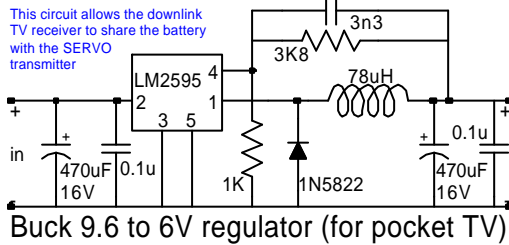

Buck 9.6 to 6V regulator (for pocket TV)

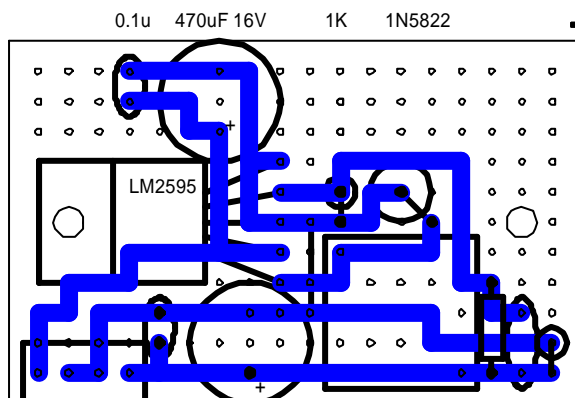

in ground out 0.1u 470uF 16V 78uH, .5ohm, 1.5A 3K8 3n3 1K
downlink TV receiver: 9.6 - 6V buck convertor

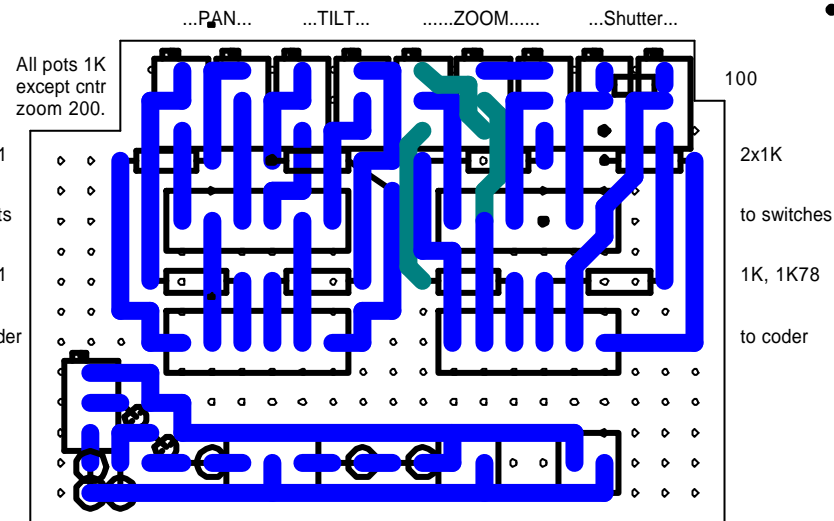

5V1/10K 12K 1K2 to LED 240 6V6 PSU PSU
Servo Transmit Coder: Control translation Layout